

## PreAP Forces 2

- Two very small people are pulling a box. Identify the four shown forces as  $F_F$  (friction);  $T$ ;  $F_W$ ;  $F_N$ .
  - \_\_\_\_\_ \*  $F_1$ — the two men pulling WITH A ROPE.
  - \_\_\_\_\_ \*  $F_2$ — the force pushing up by the floor.
  - \_\_\_\_\_  $F_3$ — the force pulling down on the mass.
  - \_\_\_\_\_  $F_4$ — the force trying to stop the mass from moving.
  - \_\_\_\_\_ Which force is in the negative x-direction?
  - \_\_\_\_\_ Which force is in the positive y-direction?
  - \_\_\_\_\_ Which force is in the positive x-direction?
  - \_\_\_\_\_ Which force is in the negative y-direction?
  - Which forces would be used in this equation:  $\Sigma F_y = ma_y$ ?
  - Which forces would be used in this equation:  $\Sigma F_x = ma_x$ ?

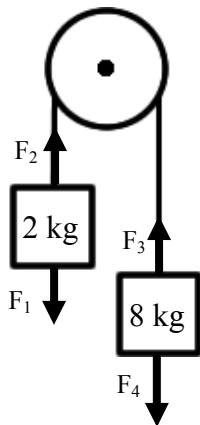
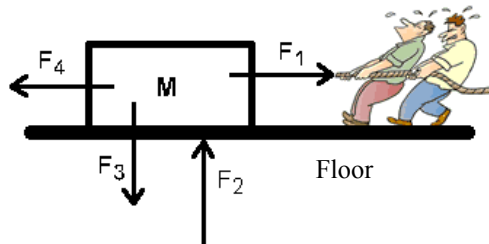

- Two masses are hanging from a rope that is threaded around a pulley, as shown. Identify the four forces.
  - \_\_\_\_\_  $F_1$  (the force pulling down on the hanging 2 kg mass).
  - \_\_\_\_\_  $F_2$  (the force of the rope pulling up on the 2 kg mass).
  - \_\_\_\_\_  $F_3$  (the force pulling up on the 8 kg mass).
  - \_\_\_\_\_  $F_4$  (the force pulling down on the 8 kg mass).
  - Which two forces are equal?                      F. Why?
  - \* Calculate  $F_1$ .    H. Calculate  $F_4$ .
  - Which forces are y-direction forces?                      J. Which forces are x-direction forces?

Use  $\Sigma F = ma$  to answer the following. The “ $\Sigma$ ” symbol is sigma and means to add up all of the forces.

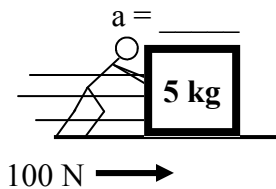
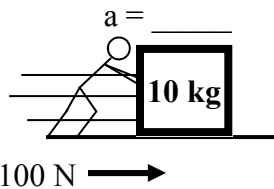
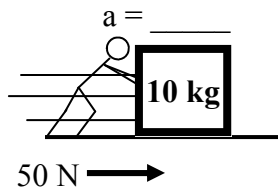

- \*Slim Jim pushes on a 10 kg mass with 50 N. Calculate (and label) the acceleration of the mass.
- Slim Jim then doubles his force. Calculate (and label) the new acceleration of the mass.
- The mass of the object is then halved. Calculate the new acceleration.
- So, from what you just learned:
  - If you double the applied force the acceleration:
  - If you half the mass, the acceleration of the object:
  - If you applied four times the force, the acceleration would be:
  - If you doubled the mass of the object, the acceleration would:

Imagine a giant air hockey table, several miles across (way cool!). Because there is a layer of air everywhere, there is NO friction. We will also assume (for you crazies) that the disk is very low and has no air resistance.

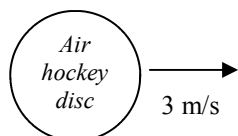

- The disc is pushed and moves with an initial velocity of 3 m/s to the right. How far will the disc go?
- Because there is no friction, what will its speed be after 40 seconds?

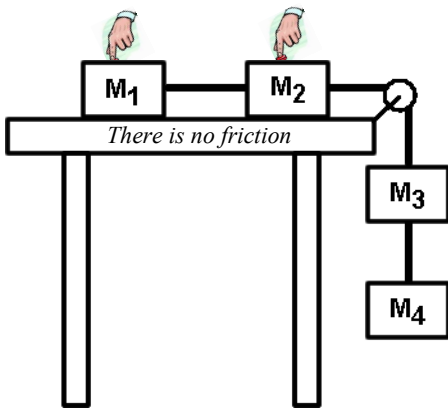

9. Four masses are connected by ropes.  
 A. Since they are not on the table, which force cannot be acting on  $m_3$  and  $m_4$ ?  
 B. \* Below are the force diagrams for the masses. Label them as  $m_1$ ,  $m_2$ ,  $m_3$  or  $m_4$ .

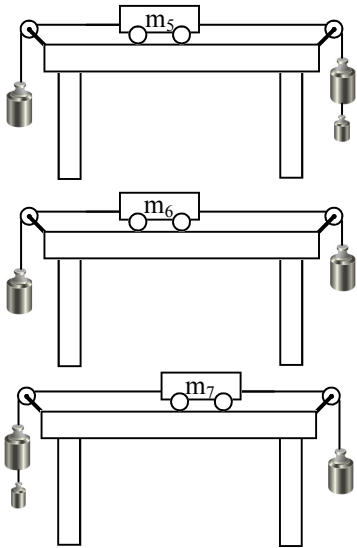
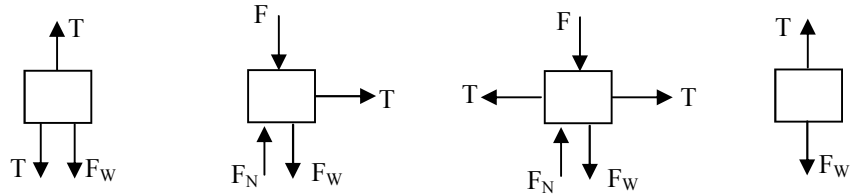

10. Use the three diagrams at the left to answer the following.
- |  |   |
|--|---|
| A. <input type="checkbox"/> Which could be at rest?              | G. <input type="checkbox"/> Could be changing direction.        |
| B. <input type="checkbox"/> Acceleration is negative.            | H. <input type="checkbox"/> Has unbalanced forces.              |
| C. <input type="checkbox"/> Acceleration is positive.            | I. <input type="checkbox"/> $v$ could = 0 m/s.                  |
| D. <input type="checkbox"/> Has a net force of 0 N.              | J. <input type="checkbox"/> Could be a constant speed.          |
| E. <input type="checkbox"/> Has a net force ( $F_{net} \neq 0$ ) | K. <input type="checkbox"/> Could be slowing down to the left.  |
| F. <input type="checkbox"/> Has balanced forces.                 | L. <input type="checkbox"/> Could be slowing down to the right. |

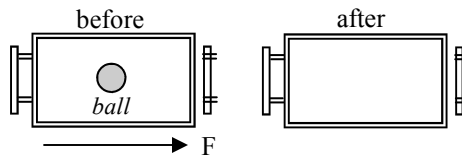

11. A force quickly pushes a cart to the right.  
 Draw where the ball ends up.

1A) Tension    1B) normal force    2G) calculate its weight =  $mg = 2(10) = 20\text{ N}$   
 3)  $F = ma$  so,  $50 = 10a$   $a = 50/10 = 5\text{ m/s}^2$   
 9B) First diagram must be mass 3, since it has no normal force and has tension pulling up and down.